

# SANDY SUMMIT PLAY CENTER

Rev. October 20-06



Setup Dimensions  
with Safety Clearance:  
22' l. x 22' w.

**I M P O R T A N T**

**1-877-WOODSET (966-3738)**

**for questions, assembly help or assistance with missing or defective parts.  
Prior to assembling your play center please read your  
Big Backyard Owners Manual.**

**Big Backyard**  
Play BIG! in any yard<sup>®</sup> by solo)wave<sup>™</sup>

solo)wave design  
375 Sligo Rd. W. • P.O. Box 10  
Mount Forest • Ontario • Canada • N0G 2L1  
Phone: 519-323-3833 • Fax: 519-323-4186  
TOLL FREE: 1-877-WOODSET (966-3738)  
[www.solowavedesign.com](http://www.solowavedesign.com)

# A B O U T O U R W O O D

Solowave Design™ uses only Premium playground lumber, ensuring the safest product for your children's use. Although great care has been taken in selecting the best quality lumber available, wood is a product of nature and susceptible to weathering (changes in the aesthetics of the wood). A light sanding may be required to remove minor splinters. For your information, we have described some changes that may occur as a result of weathering:

1. Checking – checks are surface cracks in the wood along the grain. 4" x 4" material will experience more checking than 2", 1-1/4" or 1" material because the surface and interior moisture content will vary more widely than in thinner wood.
2. Warping – warping refers to any distortion (twisting, cupping) from the true plane that may take place during weathering.
3. Fading – wood exposed to sunlight, will over time, turn a gray colour.

Note: The above changes will not affect the strength of the product.

## What Causes Weathering?

One of the main reasons for weathering is the effect of water (moisture); the moisture content of the wood at the surface is different than the interior of the wood. As the moisture moves in or out of the wood (result of climate changes), the different moisture content causes tension in the wood, which can result in checking and/or warping.

Due to changes in the climate, moisture moves in and out of the wood.

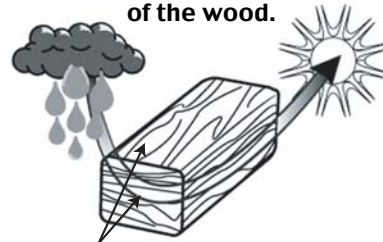

Moisture content will vary throughout any piece of wood

## How can I reduce the amount of weathering to my Play Center?

At the factory we have added water repellent to the stain. This water repellent decreases the amount of water absorption during rain or snow thus decreasing the tension in the wood. Sunlight will break down the water repellent, so we recommend applying a water repellent on a yearly basis (see your local stain/paint supplier for a recommended product). Also if storing the product before installation, make sure you store out of direct sunlight in a cool dry place.

## Will Weathering affect the Strength of my Play Center?

Most weathering is just the normal result of nature and will not affect safe play and enjoyment for your child. However if you are concerned that a part has experienced a severe weathering problem please call our consumer relations department for further assistance.

**Important Information:**  
Please ensure this page is read.

**Big Backyard**  
Play BIG! in any yard by solo)wave®

# HELPFUL HINTS

## TOOLS REQUIRED



## SWING HANGERS

Swing hangers must be screwed into the wood the full length of the shaft, so that the triangular head is touching the wood (see swing hanger diagram). Failure to correctly install swing hangers may result in the hanger itself breaking, or the hanger becoming dislodged from the wood. Either circumstance can cause serious injury. Big Backyard cannot assume any responsibility for incorrect installation of swing hangers. (Liquid soap may be used as a lubricant for ease of installation).

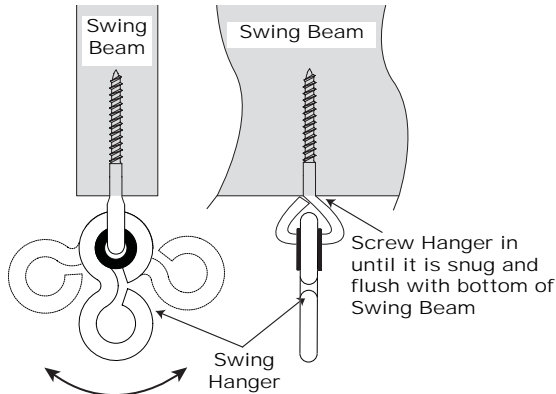

**Important Information:**  
Please ensure this page is read.

## TEE-NUTS & LOCK WASHERS

Place tee-nut in hole and tap into place with hammer. Insert the hex bolt through, first the lock washer and then the flat washer, and feed through hole. Hand tighten to ensure bolt and tee-nut connection (this may not be possible due to coating on hardware, if not use a ratchet), and then proceed with ratchet. DO NOT over tighten. Hardware should not crush wood.

A 1/4" lock washer and flat washer, are used with 1/4" hex bolt or 5/16" with 5/16".

NOTE: Follow proper assembly procedure.

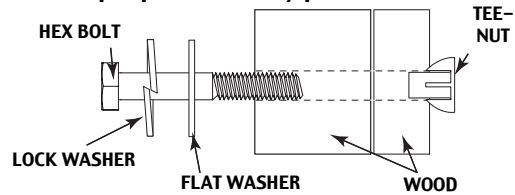

## HARDWARE

When making the selection of 1/4" and 5/16" hardware, carefully read the instructions in each step of this manual to ensure the proper hardware is used.

Note: 5/16" Hardware is larger in diameter than 1/4".

The Swing Triangle Plate has a total of 5 holes, and they are all used depending on where you are installing it. When installing the plates, pay close attention to the holes required. When complete, the swing end should be approx. 90°.

NOTE: In the event that Hex Bolt is exposed beyond the tee-nut, please disassemble, add another flat washer to head of hex bolt and then reassemble until correct.

## DOWEL INSTALLATION

1. Insert Dowel into provided holes until the shoulder of tenon is flush to the face of the Swing Rail or Access Rail or Ladder Post.
2. Pre-drill a 3" x 1/8" hole through Rail or Post prior to securing with wood screw. Securing with screw prior to pre-drilling may lead to cracking and must be avoided.
3. Secure dowel in place with appropriate wood screws as instructed within manual.

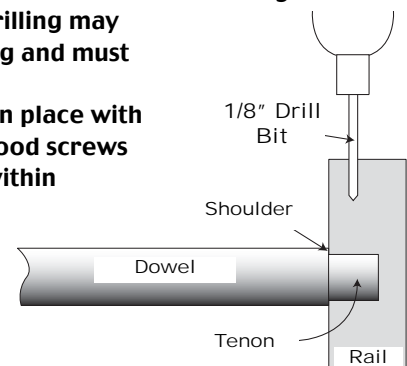

# WOOD PARTS IDENTIFICATION

Parts Identification Helpful Hints:

*Before you start assembling your fort, be sure to sort, identify, and count all of the wood parts.*

Due to the fact that wood is a natural substance, slight warping or twisting may occur while it is in the carton. However, slight twisting or warping will not affect the structural integrity of your play centre. Also, due to weather changes, expansions and contraction of wood may cause slight checking and distortion. This is a natural characteristic of wood and will not affect the structural integrity of the play centre.

Wood parts actual dimensions vary due to finishing profiles. Actual sizes are shown in this chart.

Nominal Size	Actual Size	Nominal Size	Actual Size
1" x 6"	5/8" x 5 3/8"	5/4" x 4"	1" x 3 1/2"
2" x 6"	1 3/8" x 5 3/8"	2" x 3"	1 3/8" x 2 1/2"
2" x 4"	1 3/8" x 3 3/8"	2" x 2"	1 1/2" x 1 1/2"
1" x 5"	5/8" x 4-1/2"		

(3) Access Board (1 x 6 x 19-3/4")



(1) Roof Ridge (2 x 2 x 22-3/8")

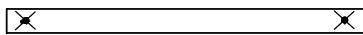

(3) Floor Support (5/4 x 4 x 39-1/2")

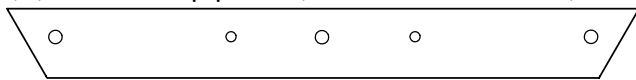

(2) Tarp Upright (2 x 3 x 47-3/4")

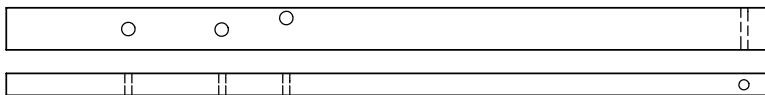

(1) Acro Support (2 x 4 x 46")



(2) Sandbox Side (1 x 5 x 79-1/2")



(1) Swing Beam (2 x 6 x 71")

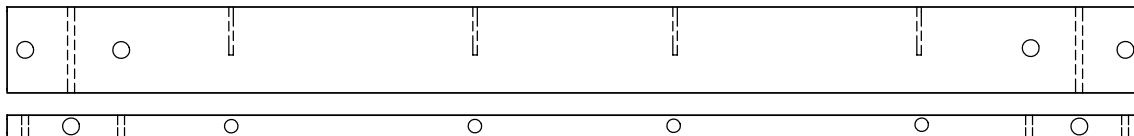

(1) Swing Post (2 x 4 x 83")

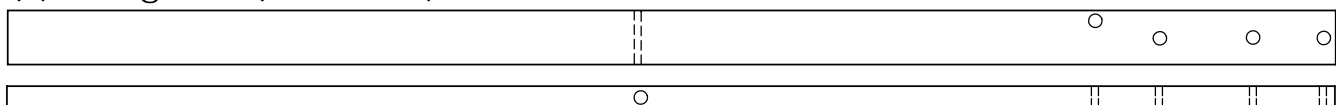

(6) Post (5/4 x 4 x 87")

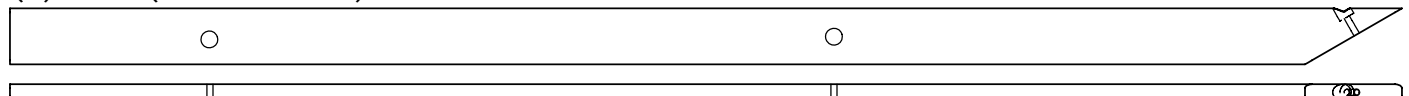

(7) Swing Block (5/4 x 4 x 3-1/2")



(1) Slide Brace (2 x 2 x 12-1/2")

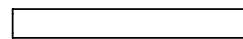

(4) Rock Board (1 x 6 x 19-3/4")

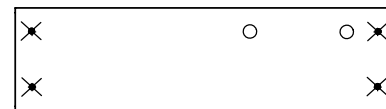

(6) Floor Board (1 x 6 x 17")

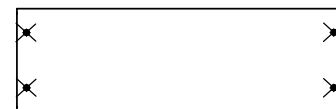

# ACCESSORY PARTS IDENTIFICATION

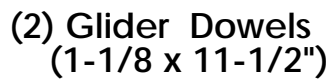
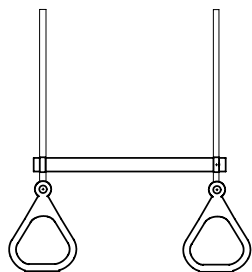
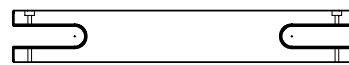
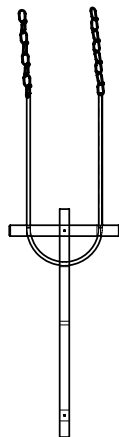
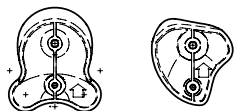
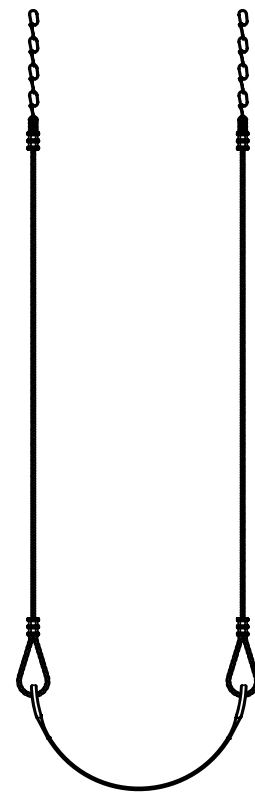
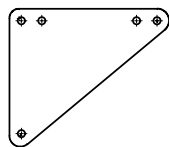
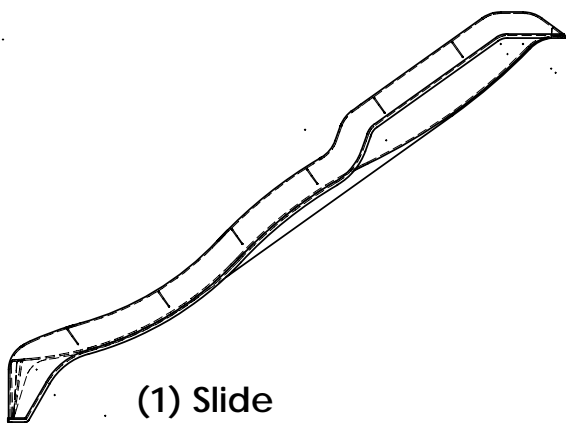
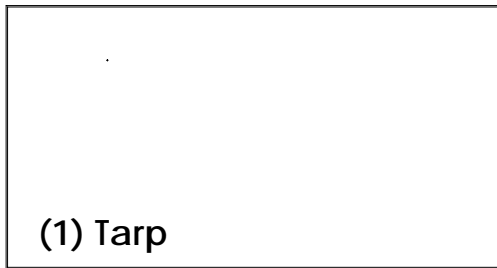

# HARDWARE PARTS IDENTIFICATION

Parts Identification Helpful Hints:

1. *Before you start assembling your fort, be sure to sort, identify, and count all of the hardware.*
2. During Assembly **DO NOT** fully tighten bolts unless instructed. Fully tightened bolts may not allow for other hole alignments.
3. Before children use the play centre, make sure all hardware is tightened, all ground stakes are installed, and any remaining wood, hardware and packaging materials are removed from the play area. Be sure not to over-tighten hardware as it will crush wood fibers and result in splintering.

**NOTE HARDWARE IS TO SCALE**

## Hardware Bag Sandy Summit

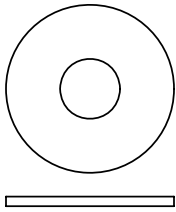
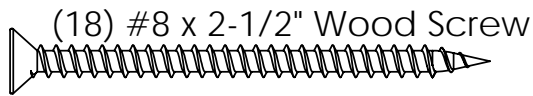
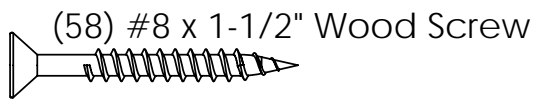

(16) 5/16" Flat Washer

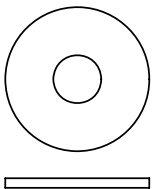

(20) 1/4" Flat Washer

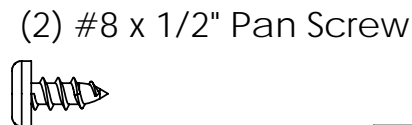
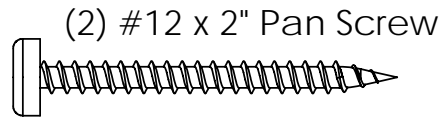
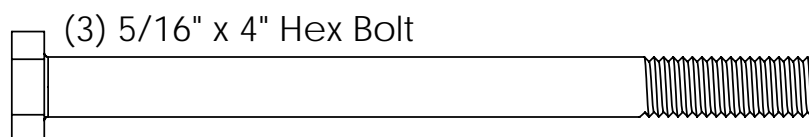
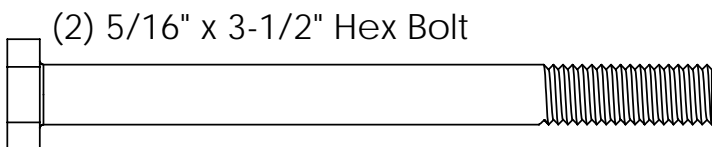
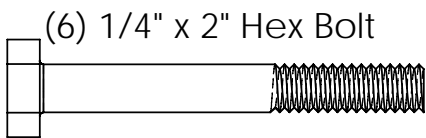

(12) 5/16" Lock Washer

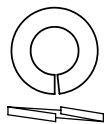

(17) 1/4" Lock Washer

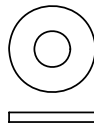

(2) #8 Flat Washer

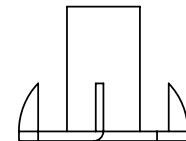
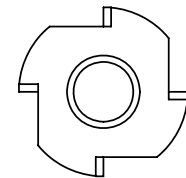

(12) 5/16" T-Nut

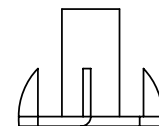
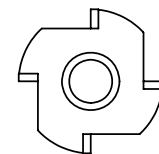

(17) 1/4" T-Nut

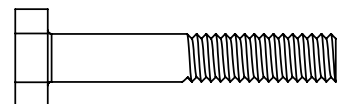

(4) 1/4" x 1-1/2" Hex Bolt

# HARDWARE PARTS IDENTIFICATION

NOTE HARDWARE IS TO SCALE

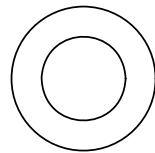
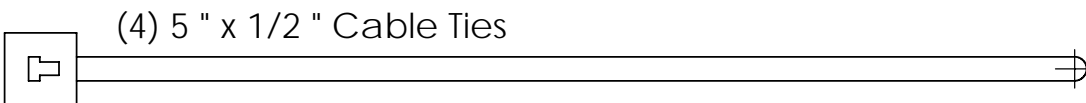
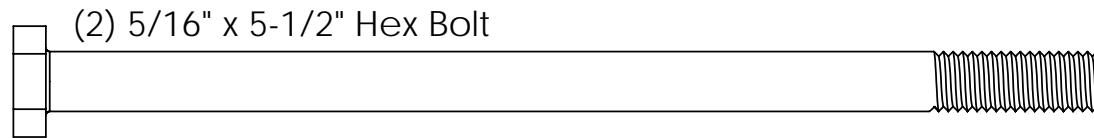
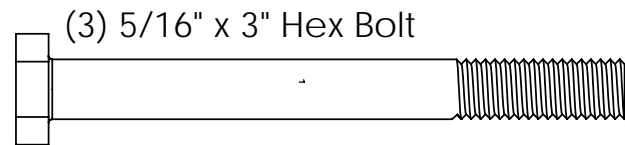
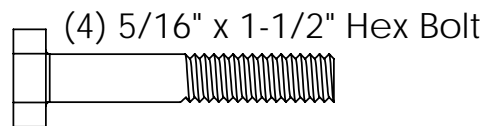
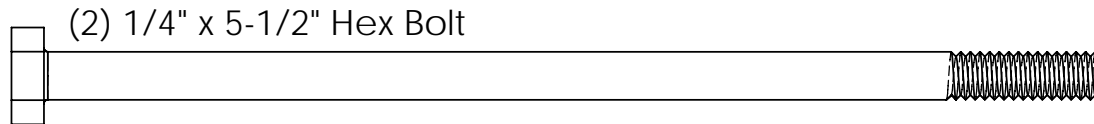
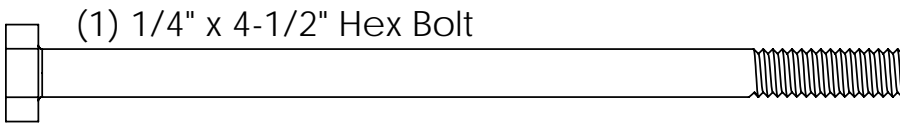
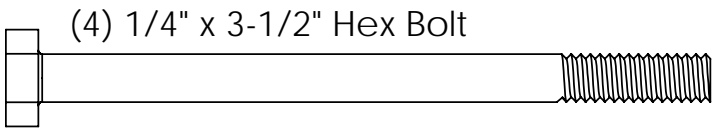
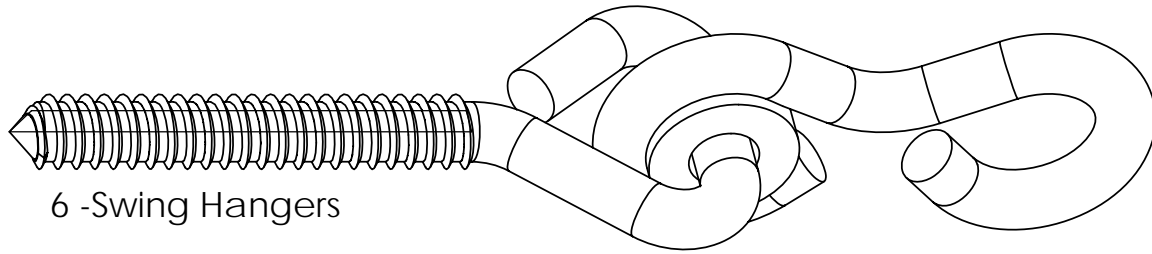

(4) 1/2" Spacer

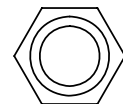
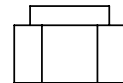

(2) 5/16" Lock Nut

# HARDWARE PARTS IDENTIFICATION

1 BAG of 4 Green Climbing Rocks  
#320184 (Hardware In Bag with Rocks)

NOTE HARDWARE IS TO SCALE

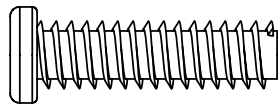

(4) 1/4" x 1-1/4"  
Pan Bolt

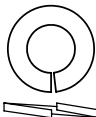

(4) 1/4" Lock  
Washer

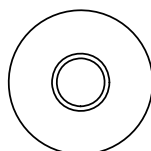

(4) 1/4" Barrel-Nut

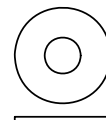

(4) 3/16" Flat Washer

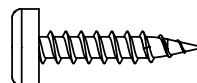

(4) #8 x 1" Pan Screw

Sandy Summit Tarp and Frame PKG  
#750681

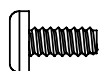

(8) #10 x 3/8" Pan Bolt

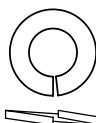

(8) #10 Lock Washers

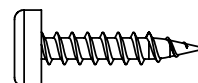

(2) #10 x 1" Pan Screw

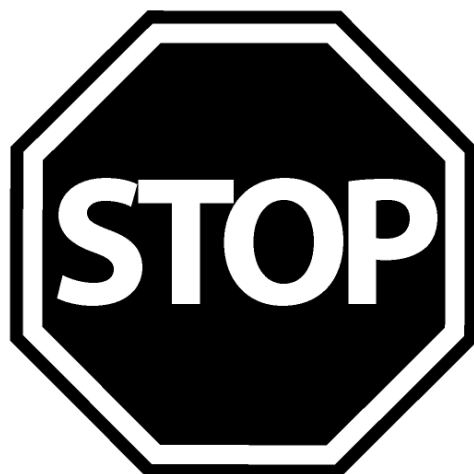

**HAVE YOU SORTED, IDENTIFIED, AND COUNTED  
ALL YOUR HARDWARE, WOOD PIECES  
AND ACCESSORIES? THIS WILL  
ASSIST YOU IN YOUR ASSEMBLY.**

**WHEN THE PARTS IDENTIFICATION IS  
COMPLETED, YOU ARE READY TO START  
ASSEMBLY.**

**IF YOU NEED ASSISTANCE,  
CONTACT THE CONSUMER  
RELATIONS DEPARTMENT  
AT 1-877-966-3738 OR  
[support@solowavedesign.com](mailto:support@solowavedesign.com)**

# STEP 1 - ASSEMBLE 2 WALLS

- A. Using 1 Hex Bolt 5/16" x 4" (5/16" T-Nut, Flat Washer & Lockwasher), attach *loosely leaving a gap between* the Tarp Upright (2" x 3" x 47 3/4") and 2 Posts (5/4" x 4" x 87").
- B. Using 2 Wood Screws (#8 x 2 1/2") per Swing Block (5/4" x 4" x 3 1/2"), attach 1 Block to the bottom of each Post. Refer to the diagram.
- C. REPEAT STEP 1 FOR OTHER SIDE.

## WARNING! Do not tighten the Hex Bolt

Follow steps in alphabetical order.  
Remember to use the proper assembly procedure for the Hex Bolt.

## HARDWARE LIST

- 2 pcs 5/16x4" Hex Bolt
- 2 pcs 5/16" T-Nut
- 2 pcs 5/16" Flat Washer
- 2 pcs 5/16" Lock Washer
- 8 pcs #8 x2-1/2" Wood Screw

## WOOD PARTS LIST

- 2 pcs 2x3x47-3/4" Tarp Upright
- 4 pcs 5/4 x4x 87" Post
- 4 pcs 5/4x4x 3-1/2" Swing Block

REMEMBER TO USE THIS ASSEMBLY PROCEDURE FOR HEX BOLTS

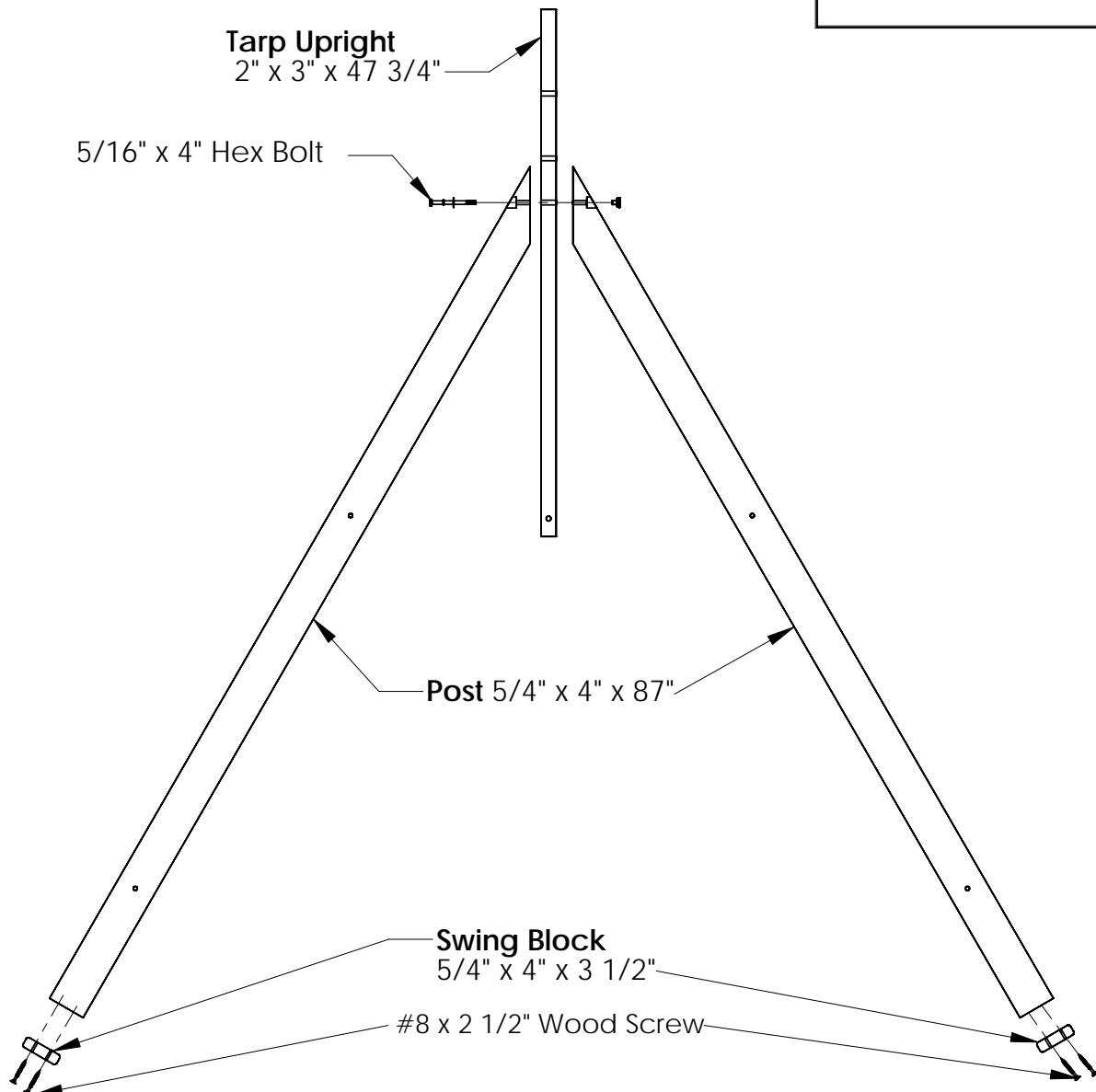
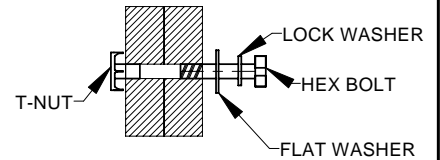

# STEP 2 - ASSEMBLE WALL SUPPORTS

- A. Using 1 Hex Bolt 5/16" x 3 1/2" (5/16" T-Nut, Washer, and Lock Washer), attach 1 Floor Support (5/4" x 4" x 39 1/2") to the Tarp Upright (2" x 3" x 47 3/4"), as per diagram below.
- B. Using 2 Hex Bolts 1/4" x 2" (1/4" T-Nut, Washer, and Lock Washer), attach the Floor Support (5/4" x 4" x 39 1/2") to the 2 Posts, as per diagram below.
- C. Using 2 Hex Bolts 1/4" x 1 1/2" (1/4" T-Nut, Washer, and Lock Washer), and 2 Wood Screws (#8 x1 1/2") attach 1 Sandbox Side (1" x 5" x 79 1/2") to the 2 Posts, as per diagram.
- D. **REPEAT STEP 2 FOR OTHER SIDE**

## HARDWARE LIST

2 pcs 5/16x3-1/2" Hex Bolt  
 2 pcs 5/16" T-Nut  
 2 pcs 5/16" Flat Washer  
 2 pcs 5/16" Lock Washer

4 pcs 1/4x2" Hex Bolt  
 4 pcs 1/4x1-1/2" Hex Bolt  
 8 pcs 1/4" T-Nut  
 8 pcs 1/4" Flat Washer  
 8 pcs 1/4" Lock Washer

4 pcs #8x1- 1/2" Wood Screw

## WOOD PARTS LIST

2 pcs 1x5x79-1/2" Sandbox Side  
 2 pcs 5/4x4x39-1/2" Floor Support

**NOTE:** Follow steps in alphabetical order.  
 Do not over-tighten Hex Bolts.  
 Remember to use the proper assembly procedure for Hex Bolts.

## NOW TIGHTEN HEX BOLT FROM STEP 1

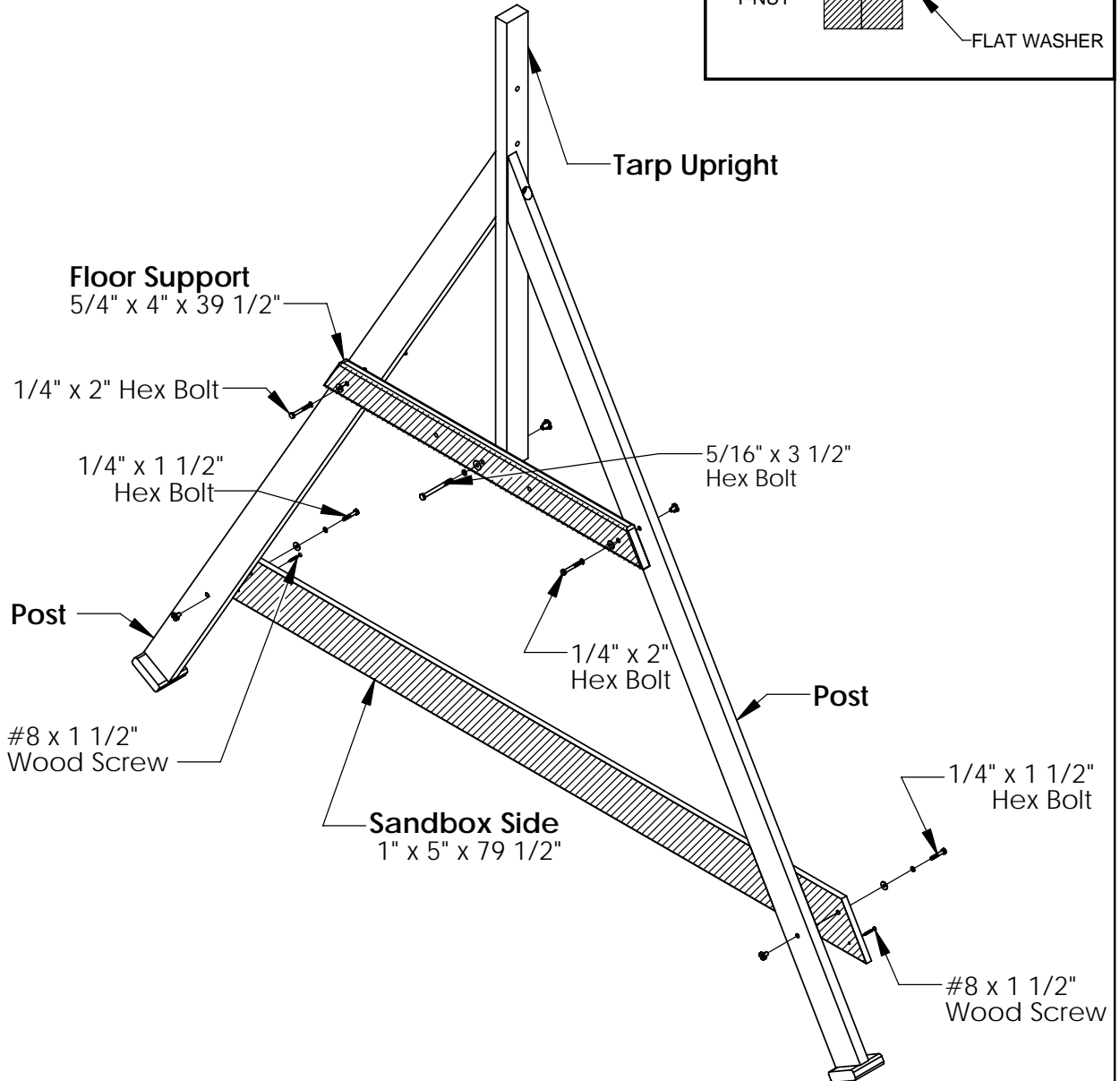
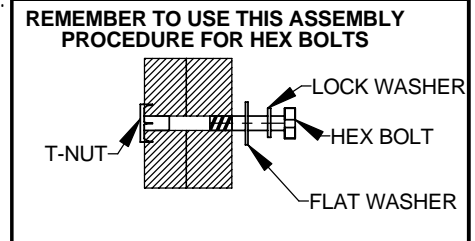

# STEP 3 - CONNECTING WALLS

**NOTE:** Before connecting the walls together, pre-drill Posts with a 1/8" drill bit. Hold the Access Boards against the 2 Posts in the proper position, before proceeding to drill. [Make sure the lower Access Boards are flush with the bottom of the Sandbox Sides, and the upper Access Board is flush with top of the Floor Support].

- A. Using 4 Wood Screws (#8 x 1 1/2") per Access Board, attach 3 Access Boards (1" x 6" x 19 3/4") to the 2 Posts. Refer to the diagram below.
- B. Using 2 Wood Screws (#8 x 3"), attach 1 Roof Ridge (2" x 2" x 22 3/8") to the 2 Tarp Uprights. Refer to the diagram below.

**NOTE:** Follow steps in alphabetical order.  
This step **may** require the help of another adult to assemble.

## HARDWARE LIST

2 pcs #8x3" Wood Screw  
12 pcs #8x1-1/2" Wood Screw

## WOOD PARTS LIST

3 pcs 1x6x19-3/4" Access Board  
1 pc 2x2x22-3/8" Roof Ridge

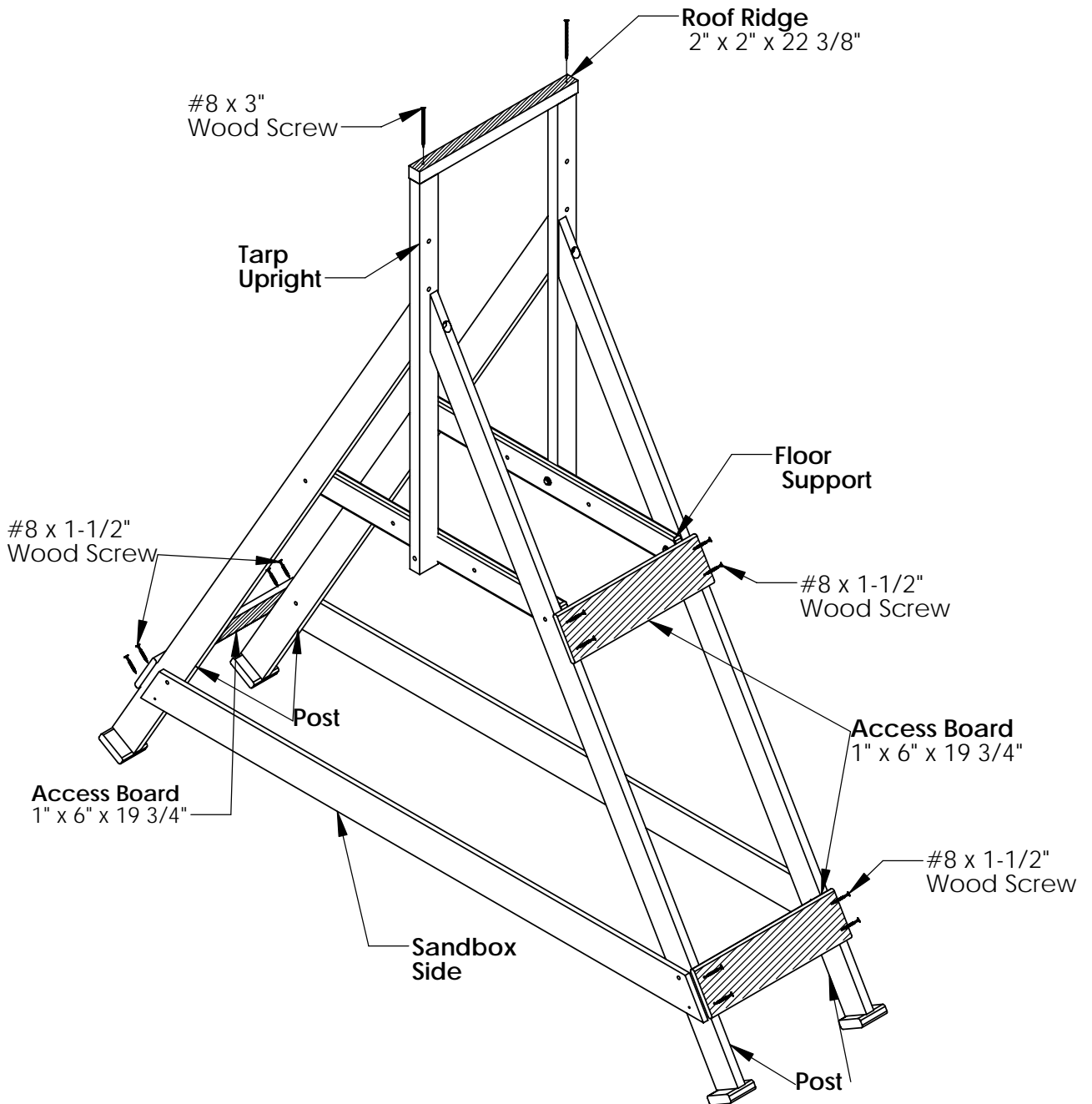

# STEP 4 - ASSEMBLE FLOOR & ROCK BOARDS

*Before assembling the Floor and Rock Boards, pre-drill Posts and Floor Supports with a 1/8" drill bit.*

Hold the Rock Board against the 2 Posts.

Make sure the Rock Boards are evenly spaced between the Access Boards, before proceeding to drill. Follow the same procedure for the Floor Boards, making sure the Floor Boards are evenly spaced on the Floor Supports.

- A. Using 4 Wood Screws (#8 x 1 1/2") per board, attach 6 Floor Boards (1" x 6" x 17") to the Floor Supports as per the diagram below.
- B. Using 4 Wood Screws (#8 x 1 1/2") per board, attach 4 Rock Boards (1" x 6" x 19 3/4") to the 2 Posts as per diagram below.

**NOTE:** Follow steps in alphabetical order.

## HARDWARE LIST

40 pcs #8x1-1/2" Wood Screw

## WOOD PARTS LIST

6 pcs 1x6x17" Floor Boards  
4 pcs 1x6x19-3/4" Rock Boards

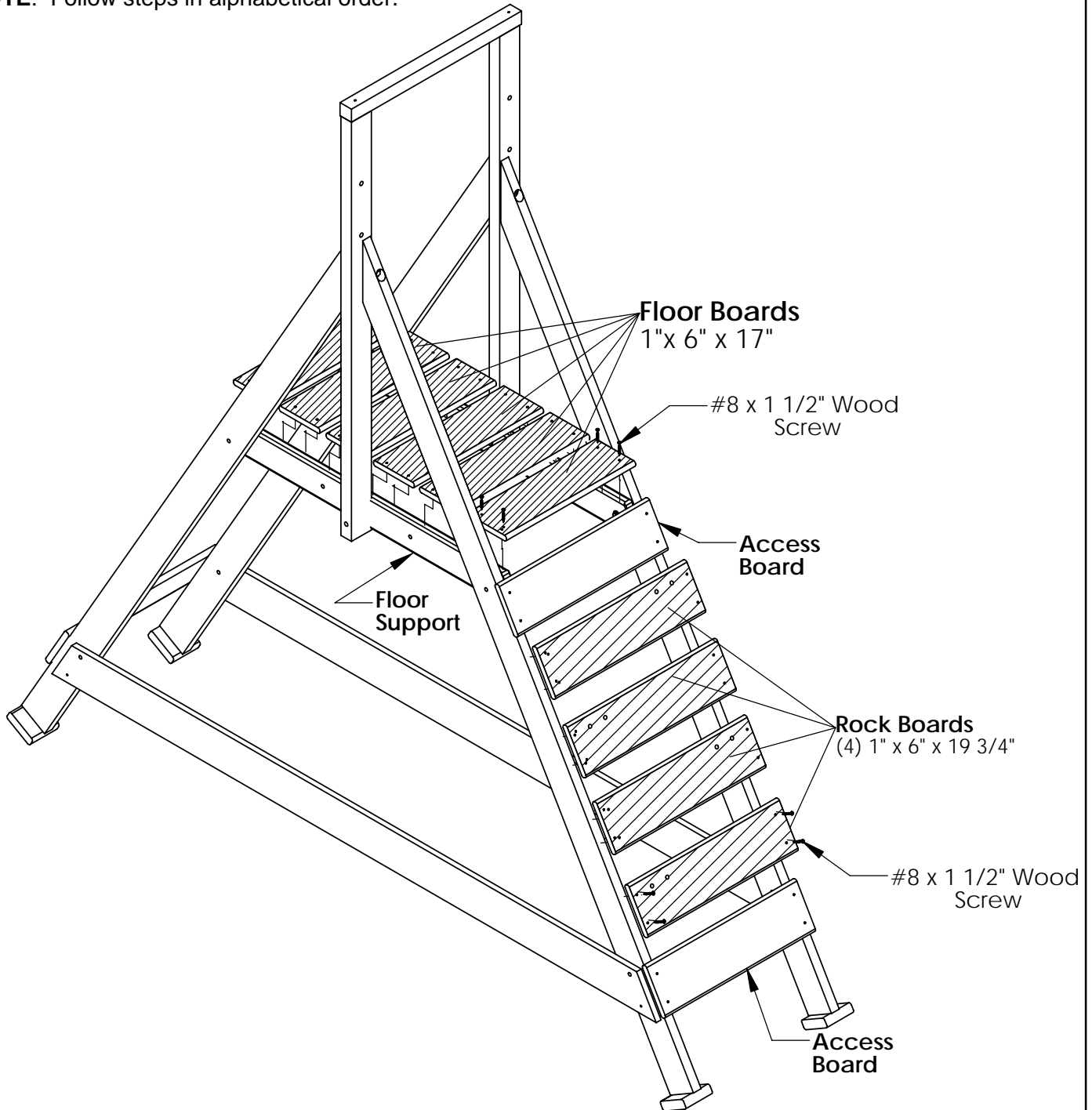

# STEP 5 - ASSEMBLE TARP ROOF & L-FRAME BRACKETS

- A. Using 2 Pan Bolts #10 x 3/8" and 2 #10 Lock Washers, connect 2 L-Frame Brackets (1/2" x 12 1/4" x 22 3/4") together. **Make sure** that the bolts go in from opposite directions, as shown in the diagram below. **Repeat for the other side.**
- B. Take one end of the Tarp and feed the L-Frame Bracket through the Tarp pocket. **Repeat for the other side.**
- C. With both L-Frame Brackets through the Tarp pockets, connect using 2 PanBolts #10 x 3/8" and 2 #10 Lock Washers for each side. **Make sure** that the bolts go in from opposite directions, as shown in the diagram below. Leave middle hole open.
- D. Centre Tarp on top of Tarp Upright, making sure it fits snug.
- E. Using 2 Pan Screws #10 x 1", fasten Tarp Assembly to the Tarp Upright using the remaining centre holes.
- F. Using 2 Pan Screws (#8 x 1/2") and 2 #8 Flat Washers, level Tarp Assembly and attach Tarp to Roof Ridge through hems in Tarp.

**NOTE:** Follow steps in alphabetical order.

## HARDWARE LIST

(Bag# 750681)

8 pcs #10 x 3/8" Pan Bolt  
 8 pcs #10 Lock Washer  
 2 pcs #10 x 1" Pan Screw  
 2 pcs #8 x 1/2" Pan Screw  
 2 pcs #8 Flat Washer

## ACCESSORY LIST

4 pcs L-Frame Brackets  
 1 Tarp

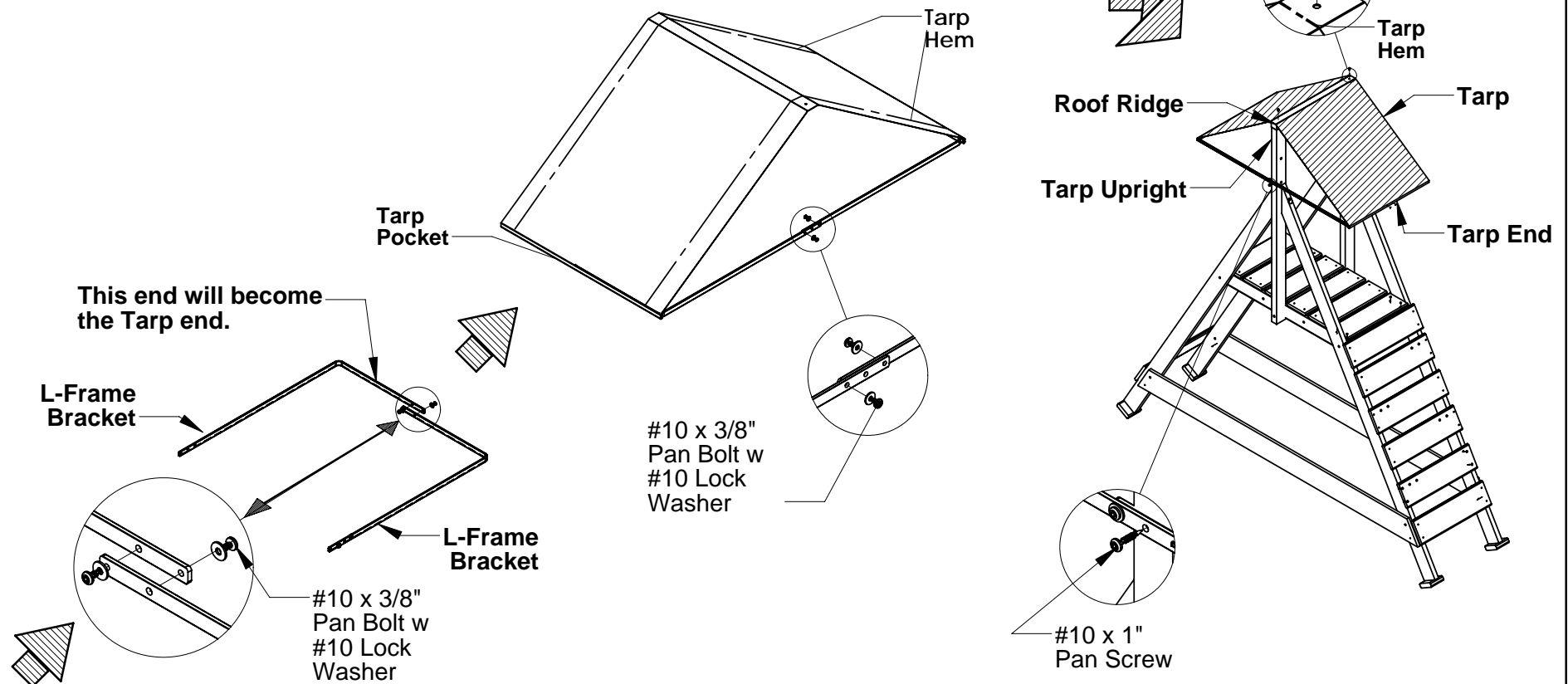

# STEP 6 - ASSEMBLE SWING END

- Using 1 Hex Bolt 5/16" x 4" (5/16" T-Nut, Washer, and Lock Washer), attach loosely leaving a gap between the 2 Posts (5/4" x 4" x 87") to the Swing Post (2" x 4" x 80 1/2") as shown in the diagram below.
- Using 1 Hex Bolt 1/4" x 4 1/2" (1/4" T-Nut, Washer, and Lock Washer), attach the Floor Support (5/4" x 4" x 39 1/2") to the Swing Post (2" x 4" x 80 1/2"), as shown in the diagram.
- Using 2 Hex Bolts 1/4" x 2" (1/4" T-Nut, Washer, and Lock Washer), attach the Floor Support (5/4" x 4" x 39 1/2") to the 2 Posts (5/4" x 4" x 87").
- Using 2 Wood Screws (#8 x 2 1/2") per block, attach 1 Swing Block (5/4" x 4" x 3 1/2") to bottom of each of the 2 Posts (5/4" x 4" x 87") and the Swing Post (2" x 4" x 80 1/2"). Refer to the diagram below.

**NOTE:** Follow steps in alphabetical order.

## HARDWARE LIST

1 pc 1/4x4-1/2" Hex Bolt  
 2 pcs 1/4x2" Hex Bolt  
 3 pcs 1/4" T-Nut  
 3 pcs 1/4" Flat Washer  
 3 pcs 1/4" Lock Washer

1 pc 5/16x4" Hex Bolt  
 1 pc 5/16" T-Nut  
 1 pc 5/16" Flat Washer  
 1 pc 5/16" Lock Washer

6 pcs #8x2-1/2" Wood Screw

## WOOD PARTS LIST

1 pc 5/4x4x39-1/2" Floor Support  
 2 pcs 5/4x4x87" Post  
 1 pc 2x4x80-1/2" Swing Post  
 3 pcs 5/4x4x3-1/2" Swing Block

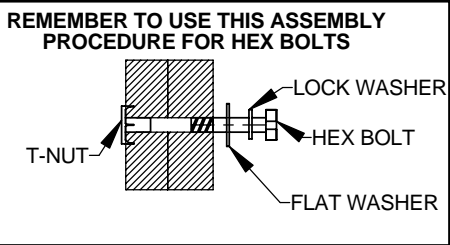

**WARNING! Do not tighten the Hex Bolt until after the Floor Support is attached**

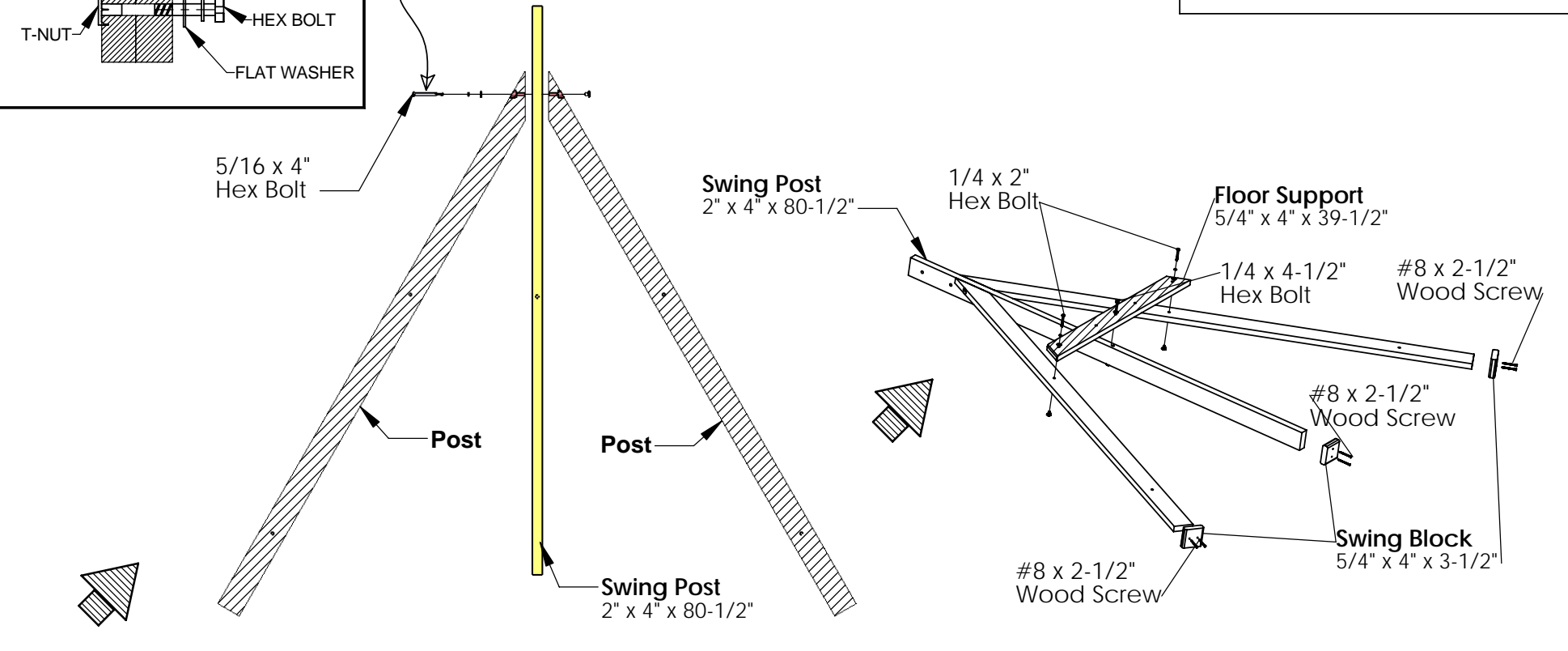

# STEP 7 - ATTACH SWING HANGERS AND TRIANGLE PLATE

- A. Using 2 Swing Hangers, screw them into the Swing Beam (2" x 6" x 71") holes from the bottom edge of the beam, as shown in the diagram. Make sure that the Swing Hangers are **snug-fit and flush** with the bottom of the Swing Beam. *Use soap as a lubricant for ease of installation.* Refer to the diagram below.
- B. Using 2 Hex Bolts 1/4" x 5 1/2" (1/4" T-Nut, Flat Washer, and Lock Washer), attach one bolt to each end of Swing Beam (2" x 6" x 71").  
**Note:** These bolts do not attach to anything, rather, they serve to provide additional strength to the Swing Beam. **This Step is mandatory.**
- C. Using 1 Hex Bolt 5/16" x 1 1/2" (5/16" T-Nut, Flat Washer, and Lock Washer), attach 1 Triangle Plate to the Swing Beam (2" x 6" x 71").  
**Make sure** to use the correct hole in the Triangle Plate. Refer to the diagram below.

## HARDWARE LIST

2 pcs 1/4x5-1/2" Hex Bolt  
 2 pcs 1/4" T-Nut  
 2 pcs 1/4" Flat Washer  
 2 pcs 1/4" Lock Washer

1 pc 5/16x1-1/2" Hex Bolt  
 1 pc 5/16" T-Nut  
 1 pc 5/16" Flat Washer  
 1 pc 5/16" Lock Washer

2 pc Swing Hanger

## WOOD PARTS LIST

1 pc 52x6x71" Swing Beam

## ACCESSORY LIST

1 pc Triangle Plate

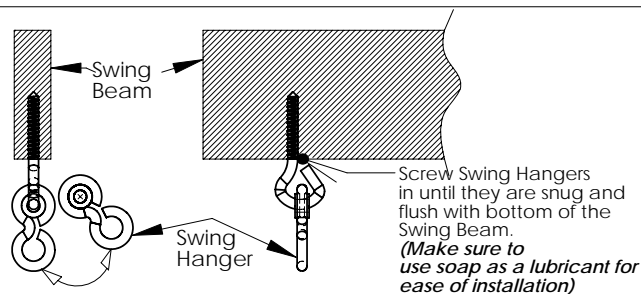
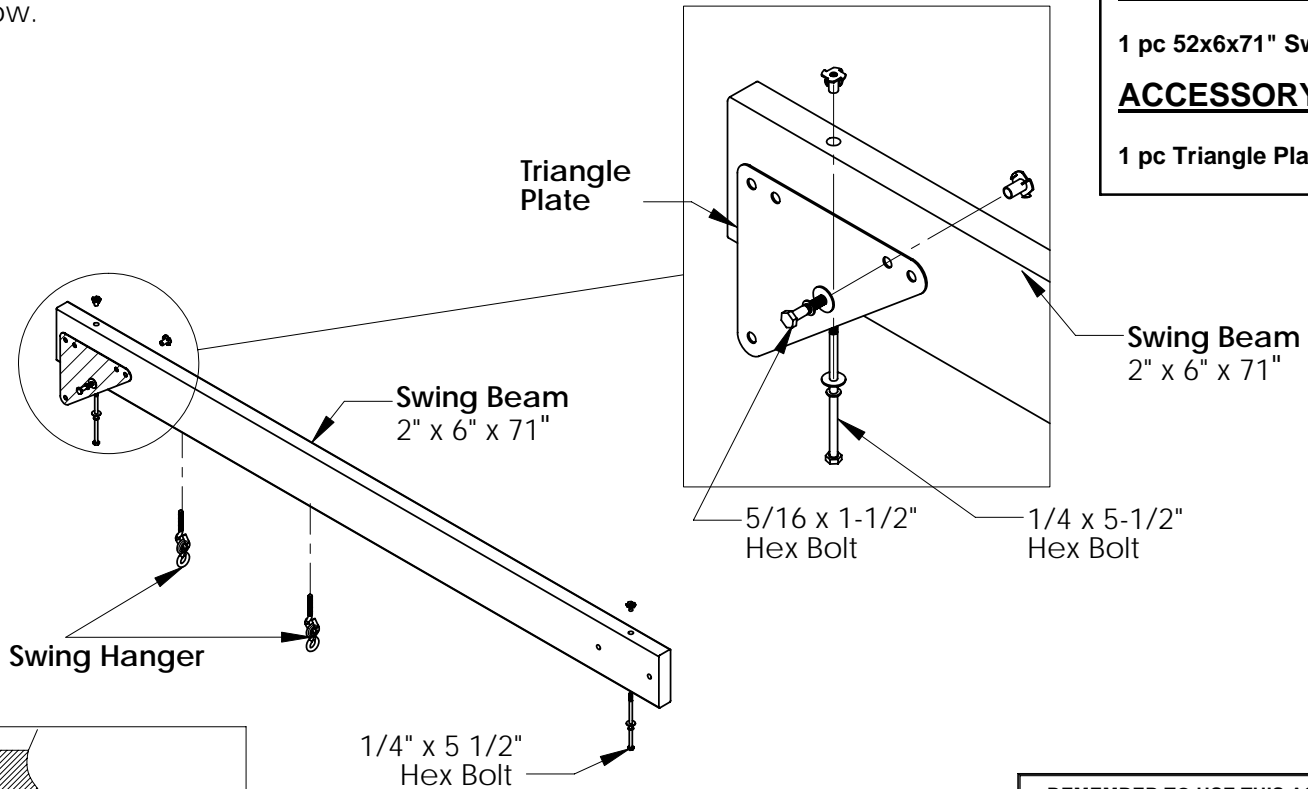
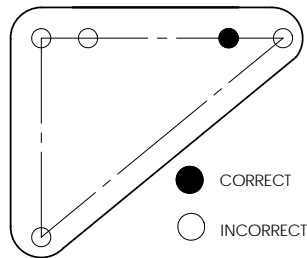

## REMEMBER TO USE THIS ASSEMBLY PROCEDURE FOR HEX BOLTS

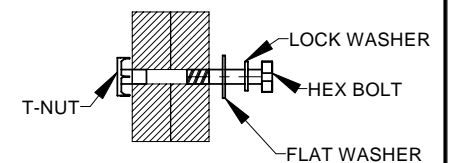

# STEP 8 - ATTACH GLIDER SUPPORTS

- A. Using 2 Swing Hangers per Glider Support, screw them into each Glider Support (2" x 4" x 15 3/4") from the bottom edge of the support as per diagram below. Make sure that the Swing Hangers are **snug-fit and flush** with the bottom of the Glider Support. Refer to the diagram below.
- B. Using 4 Hex Bolts 1/4" x 3 1/2" (1/4" T-Nut, Flat Washer, & Lock Washer), attach one bolt to each end of the Glider Supports (2" x 4" x 15 3/4").  
**Note:** These bolts do not attach to anything, rather, they serve to provide additional strength to the Glider Supports. **This Step is mandatory.**
- C. **\*Before fastening the Lag Screws, pre-drill with a 3/16" drill bit into the Glider Supports.**  
 Using 2 Lag Screws 1/4" x 4" (1/4" Flat Washer), fasten the Glider Supports to the top edge of the Swing Beam as per diagram below.  
**Note:** Align the Glider Supports with the Swing Hanger holes in the Swing Beam.

**NOTE:** Follow steps in alphabetical order.  
 Do not over-tighten Hex Bolts  
 Remember to use the proper assembly procedure for the Hex Bolts.

## HARDWARE LIST

4 pcs 1/4x3-1/2" Hex Bolt  
 4 pcs 1/4" T-Nut  
 4 pcs 1/4" Flat Washer  
 4 pcs 1/4" Lock Washer

2 pcs 1/4x4" Lag Screw  
 2 pcs 1/4" Flat Washer

4 pcs Swing Hanger

## WOOD PARTS LIST

2 pcs 2x4x15-3/4"  
 Glider Support

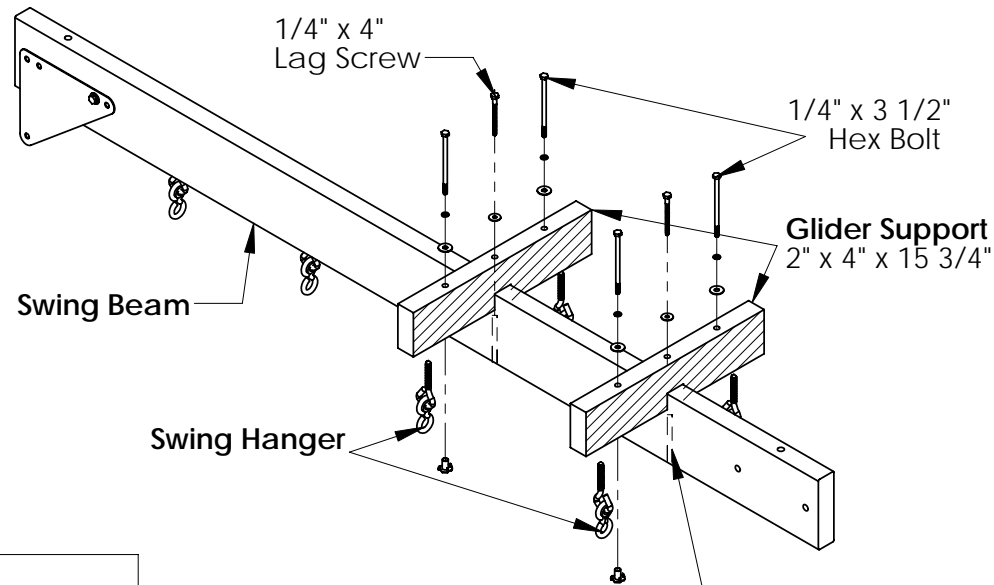

*The Lag Screw is aligned with this Swing Hanger Hole. Repeat for the other Lag Screw.*

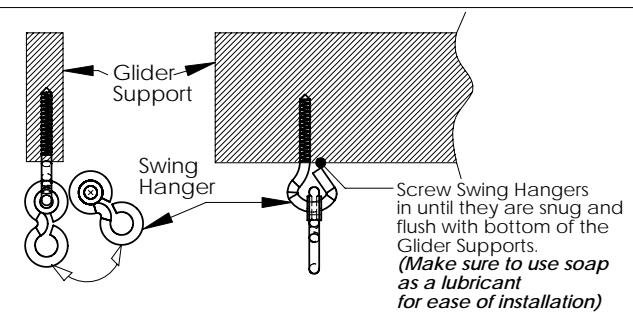
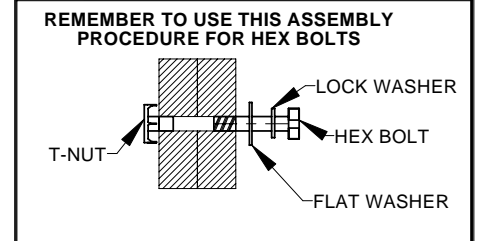
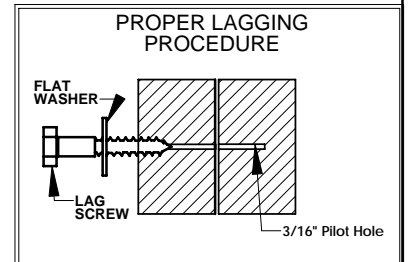

# STEP 9 - ATTACH SWING BEAM TO SWING END, ADD ACRO SUPPORT

**NOTE:** For the next steps an adult helper **may** be needed.

- Using 1 Hex Bolt 5/16" x 1 1/2" (5/16" T-Nut, Flat Washer, and Lock Washer) and 1 Hex Bolt 5/16" x 3" (5/16" T-Nut, Flat Washer, and Lock Washer), and the Triangle Plate attach the Swing Beam to the Swing Post of the Swing End from Step 6.
- Make sure** to use the correct holes in the Triangle Plate. Refer to the diagram below.
- Using 1 Hex Bolt 5/16" x 3" (5/16" T-Nut, Flat Washer, and Lock Washer) fasten the Acro Support (2" x 4"x 46") to the Swing Post.
- \*Before fastening the Lag Screws, pre-drill with a 3/16" drill bit into the Acro Support**  
Using 1 Lag Screw 1/4" x 4" (1/4" Flat Washer), attach the Acro Support to the Swing Beam.

**NOTE:** Follow steps in alphabetical order.  
Remember to use the proper assembly procedure for the Hex Bolts.  
Do not over-tighten the Hex Bolts.

## HARDWARE LIST

2 pcs 5/16x3" Hex Bolt  
1 pc 5/16x1-1/2" Hex Bolt  
3 pcs 5/16" T-Nut  
3 pcs 5/16" Flat Washer  
3 pcs 5/16" Lock Washer

1 pc 1/4x4" Lag Screw  
1 pc 1/4" Flat Washer

## WOOD PARTS LIST

1 pc 2x4x46"  
Acro Support

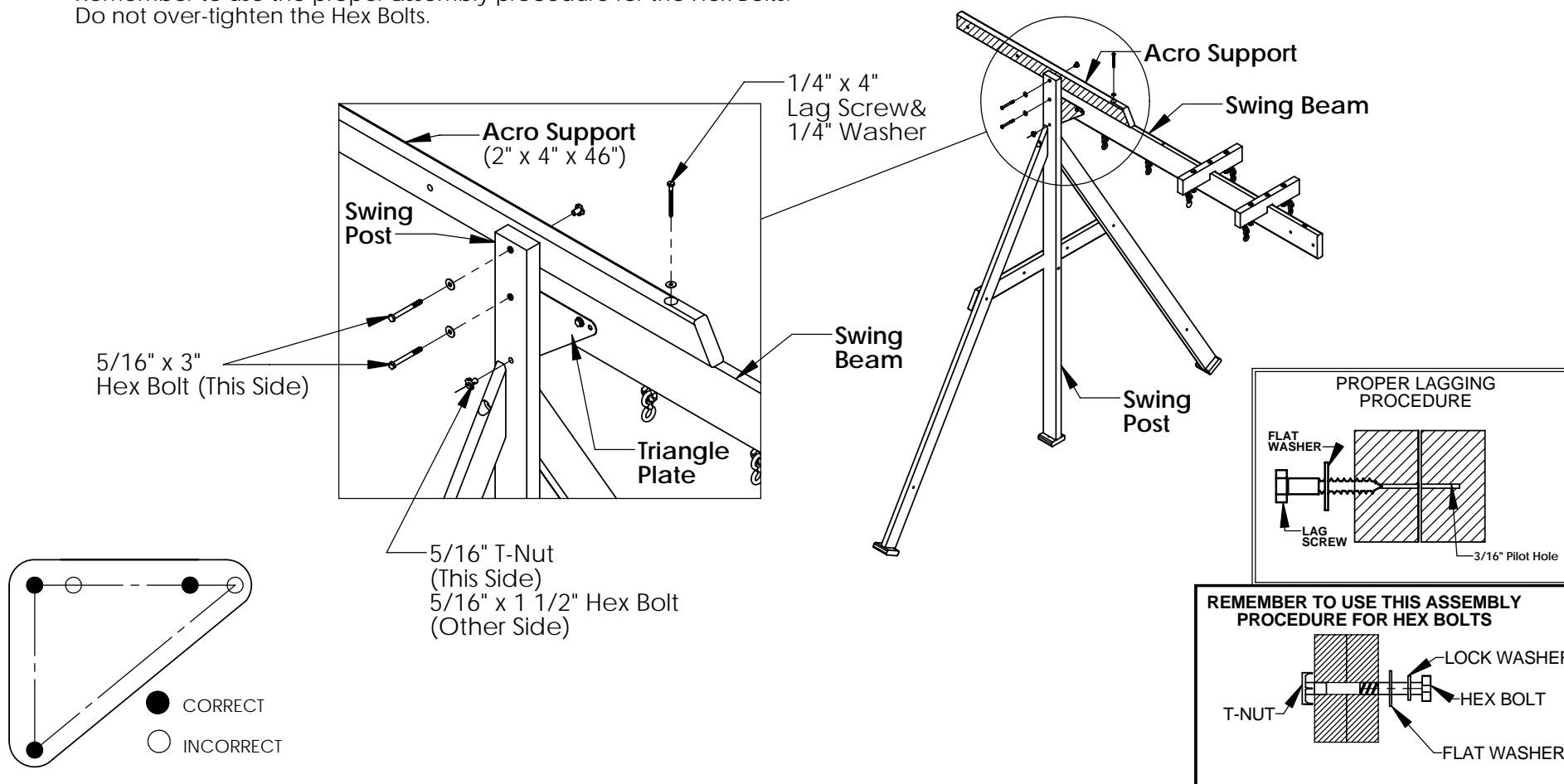

# STEP 10 - ATTACH FORT TO SWING EXTENSION

## MOVE THE FORT TO FINAL LOCATION

- A. Using 2 Hex Bolts 5/16" x 1 1/2" (5/16" T-Nut, Flat Washer, and Lock Washer) and 1 Hex Bolt 5/16" x 3" (5/16" T-Nut, Flat Washer, and Lock Washer), and 1 Triangle Plate attach the Fort created from Step 3 to the Swing Extension from Step 9. Make sure to use correct holes in the Triangle Plate as illustrated below. Remember to use the proper assembly procedure for the Hex Bolts.
- B. Using 2 Wood Screws (#8 x 1 1/2"), mount Slide Brace (2" x 2" x 12 1/2") underneath the Floor Board (1" x 6" x 17"), **making sure** the slide brace is centred and flush to the front edge of the Floor Board. Refer to the diagram below.

**NOTE: Tighten all Hex Bolts From Steps 1 - 10**

## HARDWARE LIST

- 1 pc 5/16x3" Hex Bolt
- 2 pcs 5/16x1-1/2" Hex Bolt
- 3 pcs 5/16" T-Nut
- 3 pcs 5/16" Flat Washer
- 3 pcs 5/16" Lock Washer

- 2 pcs #8x1-1/2" Wood Screw

## WOOD PARTS LIST

- 1 pc 2x2x12-1/2" Slide Brace

## ACCESSORY LIST

- 1 pc Triangle Plate

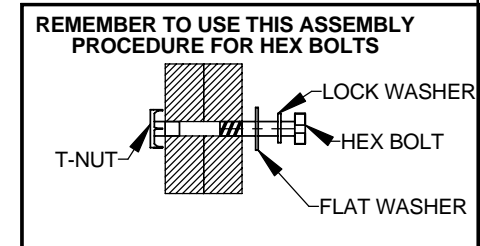
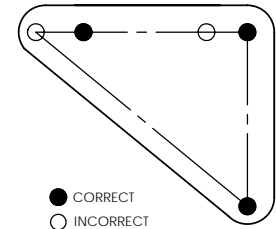
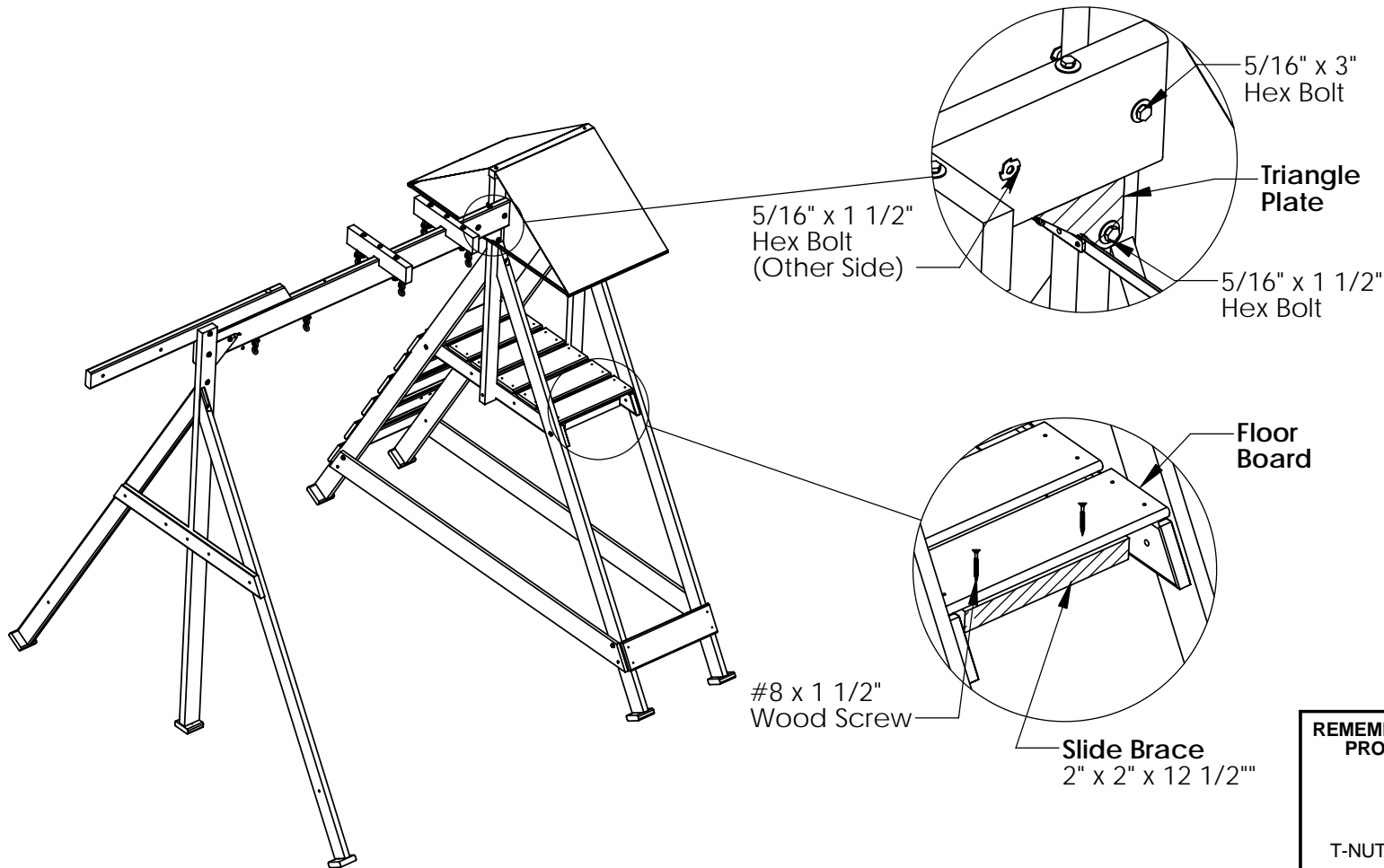

# STEP 11 - DIG HOLES THEN ATTACH SLIDE

## NOTES:

- \* Digging can be dangerous if you don't check first for underground wiring, cables or gas lines etc. Most cities and large utility companies offer a free service to locate these for you.
- \* Do not cut the Posts.

- A. With the aid of a helper, mark on the ground the resting points of the Posts. Move Fort. Dig one hole per Post 12" x 6" x 9" deep into the ground. Move Fort back. **Note:** The Swing Post hole will be dug out **only** 6" wide x 6" long x 4" deep into the ground. All other Post holes will be 6" wide x 12" long x 9" deep. Fill and pack dirt in holes.
- B. Using 2 Pan Screws (#12 x 2"), attach Slide making sure that screws go through the floor board and into the Slide Brace (2" x 2" x 12 1/2"). Refer to the diagram below.

**NOTE:** Refill holes with dirt. Compact after refilling hole about 1/3. Pack down and repeat process. Do not use any other material, such as concrete mix to fill holes.

**IMPORTANT! Level Fort before re-filling with dirt.**

## HARDWARE LIST

2 pcs #12x2" Pan Screw

## ACCESSORY LIST

1 pc Slide

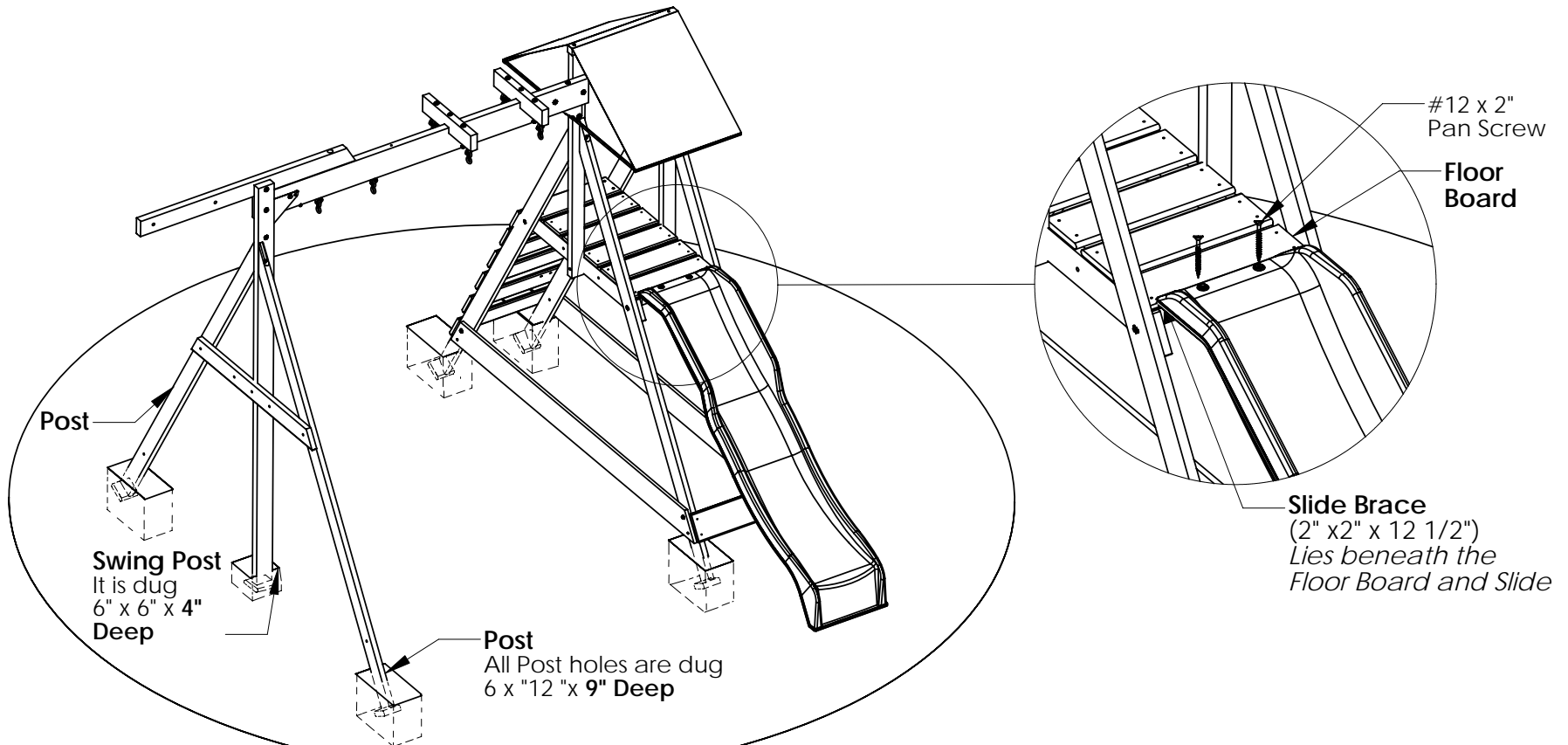

# STEP 12 - ASSEMBLE CEDAR GLIDER

\*Before fastening the Glider Dowels to the Glider Ends, *pre-drill* with 1/8" drill bit.

- Place 2 Glider Dowels (1 1/8" x 11 1/2") through the holes in the Glider Ends (5/4" x 4" x 23 3/4"), then fasten all dowels using 2 Wood Screws #8 x 2 1/2" per Glider End.
- Using 2 Hex Bolts 5/16" x 5 1/2" [(4)5/16" Washers, (2)Lock Nuts, (4)1/2" Spacers] fasten the Glider Seat (2" x 6" x 35 1/2") to the Glider Ends. **Note:** Refer to the Bolting Procedure for the Glider Seat as shown below. **Do not** over-tighten the bolts.

## HARDWARE LIST

- 2 pc 5/16x5-1/2" Hex Bolt
- 4 pcs 1/2" Spacers
- 4 pcs 5/16" Flat Washer
- 2 pcs 5/16" Lock Nut
- 4 pcs #8 x 2-1/2" Wood Screw

## WOOD PARTS LIST

- 2 pcs 1-1/8x11-1/2" Glider Dowel
- 2 pcs 5/4x4x23-3/4" Glider End

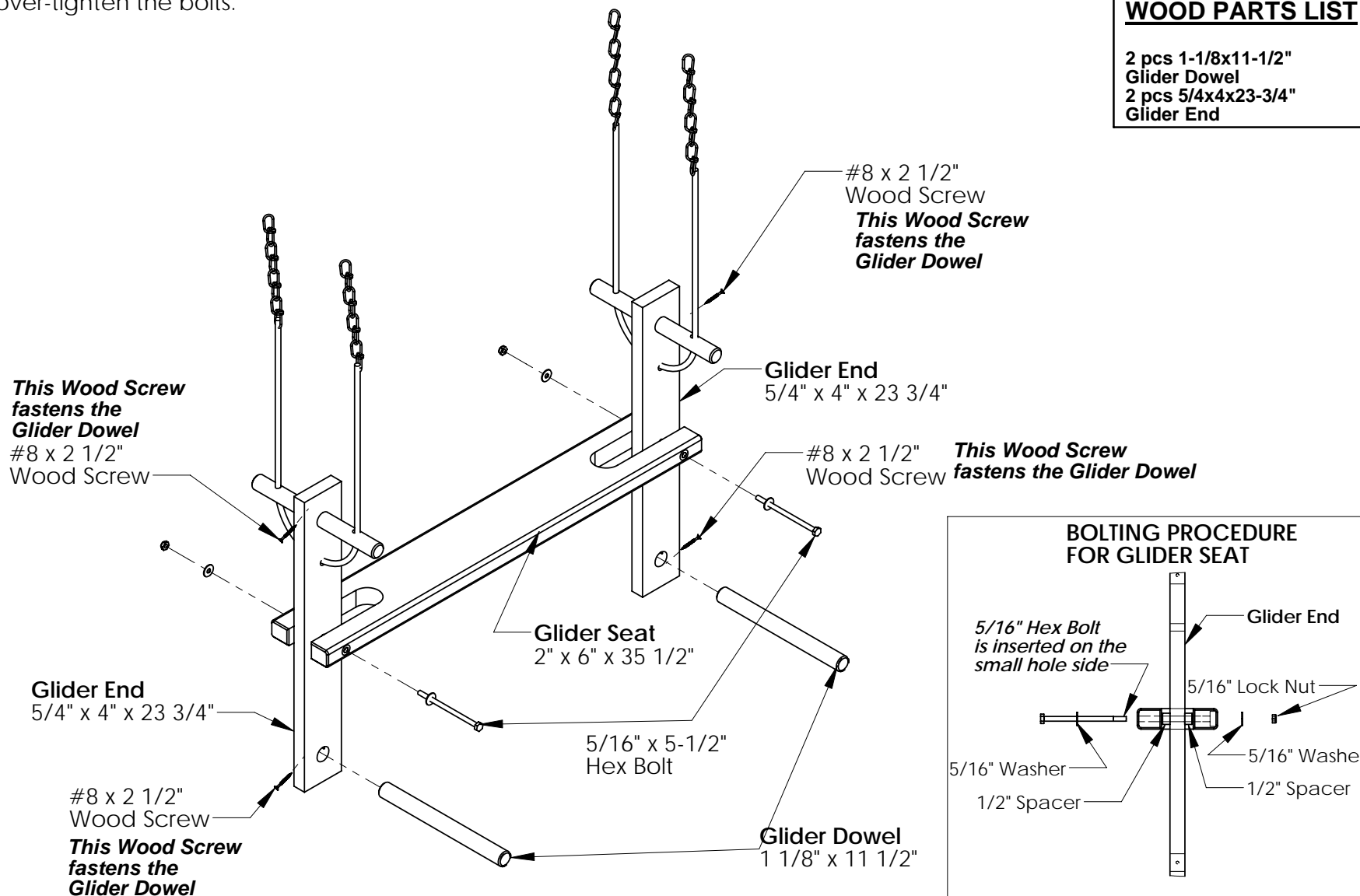

# STEP 13 - ADDING ACCESSORIES

A. Using 4 Pan Bolts 1/4" x 1 1/4", (3/16" Flat Washers, 1/4" Lock Washers, and 1/4" Barrel Nuts), attach 4 Rocks to 4 Rock Boards. Make sure to use the correct holes in rocks.

You can use any hole in each board, but only 1 Rock per Board.

**Note:** The holes should be vertically aligned with the Pan Bolt on top and the Pan Screw on the bottom, as displayed in the diagram.

B. Using 4 Pan Screws (#8 x 1"), screw into remaining hole on the Rocks.

C. Attach 1 Belt Swing and Cedar Glider to the 6 Swing Hangers.

D. Finally attach the Acro Swing. **Note:** The rope can not be less than 10" long.

**Note:** When attaching the Acro Swing, knot the swing rope securely to the Acro Support prior to securing the Cable Ties. Pull on Acro Handles to ensure knot is tight.

Cut off excess Cable Tie while ensuring that the cut end is not sharp. See Cable Tie Detail.

\* Remember to use the proper assembly procedure for attaching the Rocks.

## HARDWARE LIST

(Hardware Bag# 320184)

- 4 pcs 1/4x1-1/4" Pan Bolt
- 4 pcs 1/4" Barrel Nut
- 4 pcs 1/4" Lock Washer
- 4 pcs 3/16" Flat Washer
- 4 pcs #8x1" Pan Screw
- 4 pcs Cable Tie

## ACCESSORY LIST

- 1 Acro Support
- 1 Belt Swing
- 1 Cedar Glider
- 4 Climbing Rocks

### SIDE VIEW

Cable Tie Detail

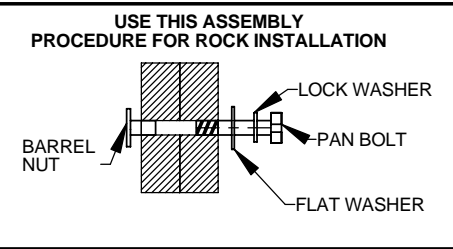
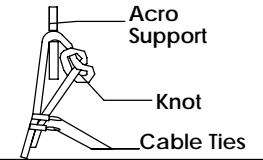

- 1/4" x 1 1/4"
- Pan Bolt
- 1/4" Lock Washer
- 3/16" Flat Washer

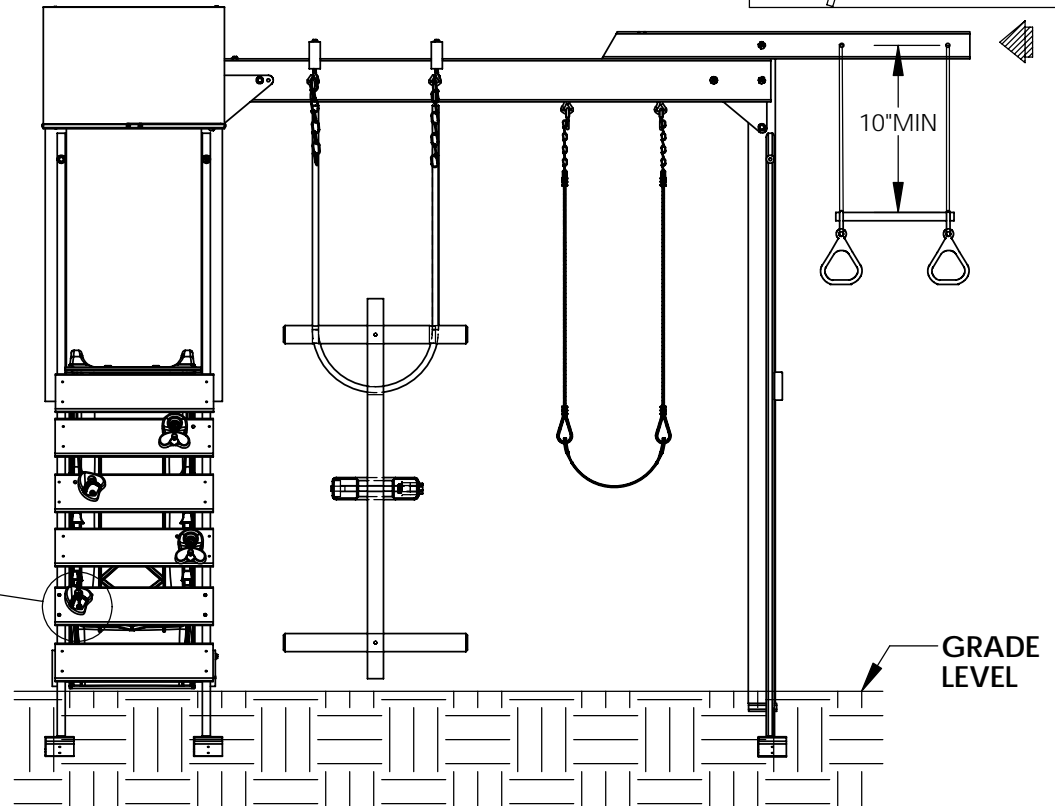
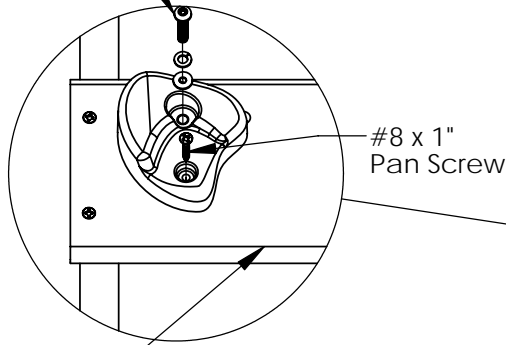

# ATTENTION

**\*DURING PEAK PLAY SEASON, PERIODICALLY CHECK AND RE-TIGHTEN ALL HEX BOLTS, LAG BOLTS, AND WOOD SCREWS TO ENSURE SAFETY. DO NOT OVER TIGHTEN TO AVOID CRUSHING WOOD.**

**\*THOROUGHLY READ INSTRUCTIONS AND THE OWNERS MANUAL BEFORE USING PLAY CENTRE.**

# SANDY SUMMIT SAFETY CHECKLIST

Please make sure that the following criteria have been met prior to allowing children to play on your fort:

Swing Beam Check Bolts are installed!

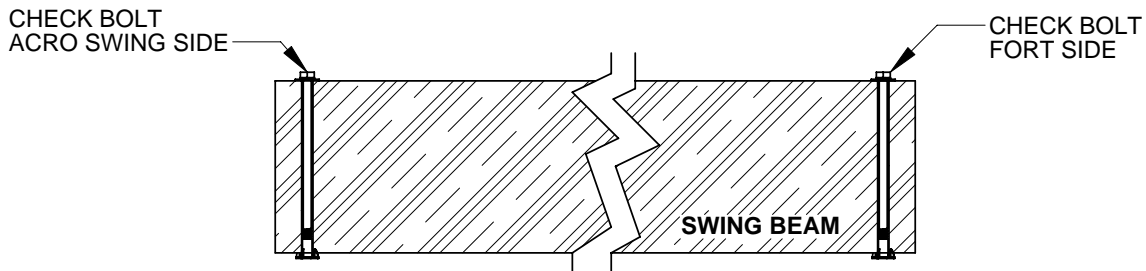

Triangle Plate Holes have correct bolt pattern!  
(Please see Triangle Plate installation Steps 7, 9-10)

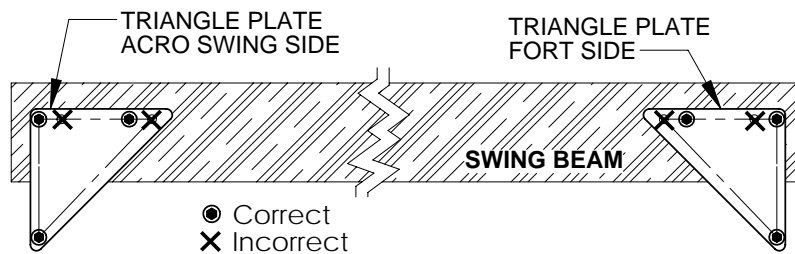

Posts and Swing Post are dug to correct depths! (Step 11)

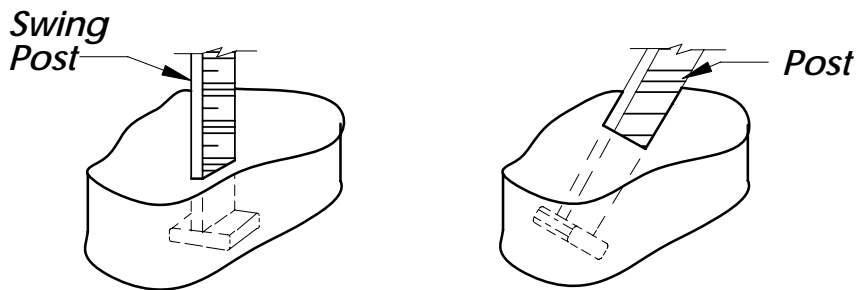

Fort is level to the ground!

